



HEIDENHAIN



Digital Readouts

Linear Encoders

For Manually Operated
Machine Tools

Digital readouts from HEIDENHAIN are used in a wide variety of applications. They are deployed on machine tools, infeed axes on saws and presses, measuring and inspection equipment, dividing apparatuses, setting tools, production inspection measuring stations and more. To meet such demands, these digital readouts can also be used in combination with numerous encoders from HEIDENHAIN.

Digital readouts with multiple axes are primarily used on manually operated machine tools, where their practical cycles provide optimal support to the operator during milling, drilling, or turning. By instantly displaying the position in an easy-to-read manner, digital readouts enable a significant increase in productivity. This brochure also includes the major HEIDENHAIN linear encoders for position measurement on manually operated machine tools.

Additional connectable encoders can be found online at www.heidenhain.com, or in the *Linear Encoders For Numerically Controlled Machine Tools*, *Length Gauges*, *Angle Encoders*, and *Rotary Encoders* brochures.

In addition to digital readouts, HEIDENHAIN offers evaluation units commonly used on SPC inspection stations, profile projectors, measuring microscopes and manually operated coordinate measuring machines. These **evaluation electronics for metrology applications** feature either an integrated display or a connection for a PC.

You can find more information online at www.heidenhain.com, or in the *Evaluation Electronics For Metrology Applications* brochure.

For detailed descriptions of all available interfaces, as well as general electrical information, please refer to the *Interfaces of HEIDENHAIN Encoders* brochure.

This brochure supersedes all previous editions, which thereby become invalid. The basis for ordering from HEIDENHAIN is always the brochure edition valid when the order is placed.

Standards (ISO, EN, etc.) apply only where explicitly stated in the brochure.



Contents

Digital readouts		
Overview	HEIDENHAIN digital readouts	4
	Selection guide	6
Functions	Probing functions for presets	8
	Tool compensation	9
	Distance-to-go display	10
	Hole patterns	11
	Aids for working with lathes	12
	Programming of machining steps	13
Specifications	ND 5000 Digital readout for milling machines, drilling machines and lathes with up to three axes	14
	ND 7000 Digital readout for milling machines, drilling machines and lathes with up to three axes	16
	POSITIP 8000 Digital readout for milling machines, drilling machines and lathes with up to six axes	20
	Mounting and accessories	24
Linear encoders for machine tools		
Overview		30
Specifications	LS 300 series	32
	LS 600 series	34

HEIDENHAIN digital readouts

High convenience

Digital readouts from HEIDENHAIN are universally deployable: they can be used in standard milling, drilling and turning applications, and in many other machine tools and specialized machine applications; in short, on all machines and equipment with manually operated axis slides.



Versatile, ergonomic and well designed

Digital readouts from HEIDENHAIN are particularly user-friendly.

Typical characteristics:

- Optimally readable display
- Graphical support and help functions
- Conversational user guidance
- Splash-protected front panel (prevents coolant from damaging your digital readout)
- Sturdy housing built for the harshest day-to-day shopfloor conditions



Ease of operation

Fast

HEIDENHAIN digital readouts save you time. Their distance-to-go mode, for example, guides you quickly and reliably to the next nominal position. You simply move the axis until the display reads zero. Presets can be set wherever the reference point for the dimensions may lie. This makes positioning easier, especially on workpieces with complex dimensions.

For milling and drilling, entering the geometric data for hole patterns or rectangular pockets is fast and easy. Afterwards, you simply move to the positions shown in distance-to-go mode.

For lathes, the sum display for the saddle and top slides helps you with precision positioning. If taper dimensions in the drawing are incomplete, the digital readouts can help you calculate the taper angles.

Small-batch production is particularly easy, because repetitive machining sequences can be stored as programs and then used as often as you require.

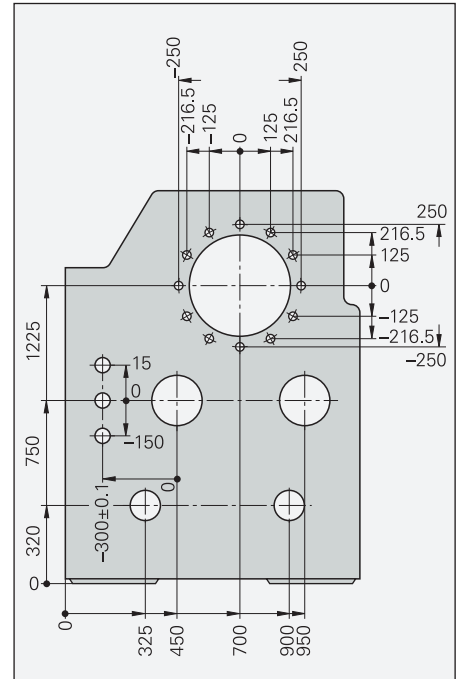

Reliable

The easy-to-read display shows the positions relative to the selected preset, thereby reducing the probability of error and making machining more reliable.

The graphical positioning aid of the POSITIP 8000, ND 5000 and ND 7000 makes distance-to-go mode even faster and more reliable. Graphical illustrations help you correctly enter the geometric data.



Accurate

On older machine tools, precision machining in the hundredths range is often a matter of luck. This is because worn machine elements make exact dial and vernier settings impossible. Linear encoders from HEIDENHAIN, however, measure the motion of the axis slides directly. As a result, any backlash from mechanical transmission elements such as lead screws, racks, or gears has no effect. Being able to directly read the slide position improves your machining accuracy and reduces scrap rates.



Selection guide

	Number of axes	Reference points / tool data	Functions
ND 5000 Digital readout for milling machines, drilling machines and lathes with up to three axes <ul style="list-style-type: none"> • Membrane keyboard 	Up to 3	10 presets; 16 tools	<i>General:</i> <ul style="list-style-type: none"> • Distance-to-go mode with graphical positioning aid <i>Milling and drilling:</i> <ul style="list-style-type: none"> • Hole patterns (circular and linear) • Tool compensation <i>Turning:</i> <ul style="list-style-type: none"> • Radius/diameter display • Separate/sum display
ND 7000 Digital readout for milling machines, drilling machines and lathes with up to three axes <ul style="list-style-type: none"> • Touchscreen operation • Switching inputs/outputs (ND 7013 I/O) • Program memory (PGM software option) 	Up to 3	100 presets; 100 tools	<i>General:</i> <ul style="list-style-type: none"> • Distance-to-go mode with graphical positioning aid <i>Milling and drilling:</i> <ul style="list-style-type: none"> • Hole patterns (circular and linear) • Tool compensation • Probing functions for presets <i>Turning:</i> <ul style="list-style-type: none"> • Radius/diameter display • Separate/sum display • Constant cutting speed (ND 7013 I/O)
POSITIP 8000 Digital readout for milling machines, drilling machines and lathes with up to six axes <ul style="list-style-type: none"> • Touchscreen operation • Program memory • Switching inputs/outputs Distance control with the POSITIP 8016 ACTIVE	Up to 6	100 presets; 100 tools	<i>General:</i> <ul style="list-style-type: none"> • Distance-to-go mode with graphical positioning aid • Contour monitoring • Programming of machining steps <i>Milling and drilling:</i> <ul style="list-style-type: none"> • Hole patterns (circular and linear) • Tool compensation • Probing functions for presets • Roughing out of rectangular pockets <i>Turning:</i> <ul style="list-style-type: none"> • Radius/diameter display • Separate/sum display • Constant cutting speed (POSITIP 8016 ACTIVE)

Encoder inputs	Switching inputs and outputs	Data interface	Page
TTL	–	USB	14
\sim 1 V _{pp} \sim 11 μ A _{pp} EnDat 2.2	<ul style="list-style-type: none"> • For KT edge finder • Others via ND 7013 I/O 	Ethernet, USB	16
\sim 1 V _{pp} \sim 11 μ A _{pp} EnDat 2.2	<ul style="list-style-type: none"> • For KT edge finder • Others via POSITIP 8016 ACTIVE 	Ethernet, USB	20



Functions

Probing functions for presets

Setup made easy with probing functions

The HEIDENHAIN KT edge finder makes finding presets especially easy: you simply move the edge finder toward the edge of the workpiece until the stylus deflects. The display automatically stores the exact position, taking into account the direction of approach and the radius of the stylus.

- Workpiece edge as reference line
- Workpiece centerline as reference line
- Circle center as preset

Preset finding with a tool

The probing functions can also be performed using a tool.

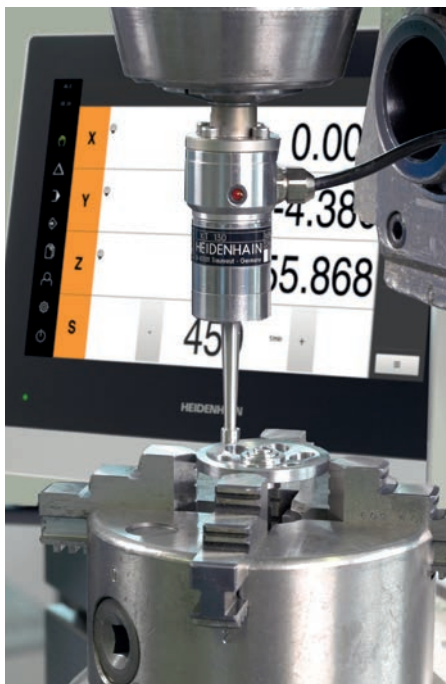
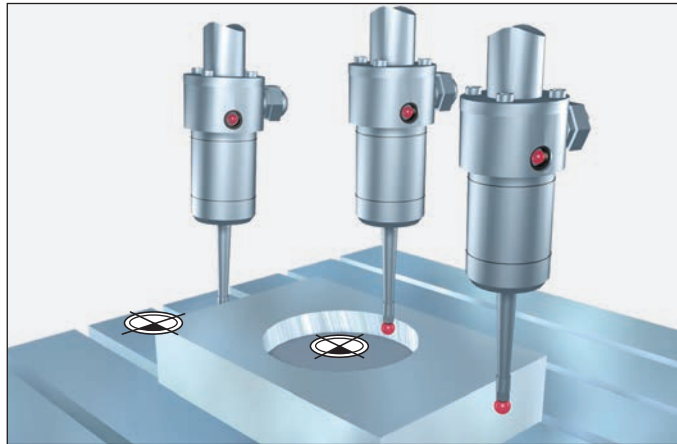

Accessory: KT edge finder

The KT edge finder is a triggering edge finder. Its cylindrical probe contact is attached to the stylus, which is spring-mounted to the housing of the edge finder. Upon contact with the workpiece, the stylus is deflected and a switching signal is output to the digital readout over the cable.

The KT edge finder allows you to find presets with greater speed and convenience without leaving marks on the workpiece.

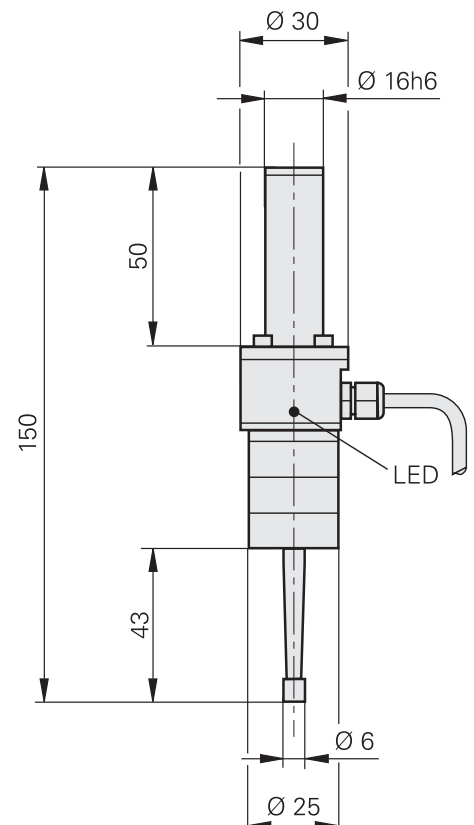

Tool compensation

Tool compensation for milling machines

The digital readouts of the ND 5000, ND 7000 and POSITIP 8000 series can save tool data, i.e., the diameter and length of the tool in use. Data from already preset tools or tool data collected on the machine can be conveniently stored in a tool table and re-activated at any time.

During positioning in distance-to-go mode, the readouts take into account the tool radius (R+ or R-) in the machining plane, as well as the tool length (ΔL) in the spindle axis.

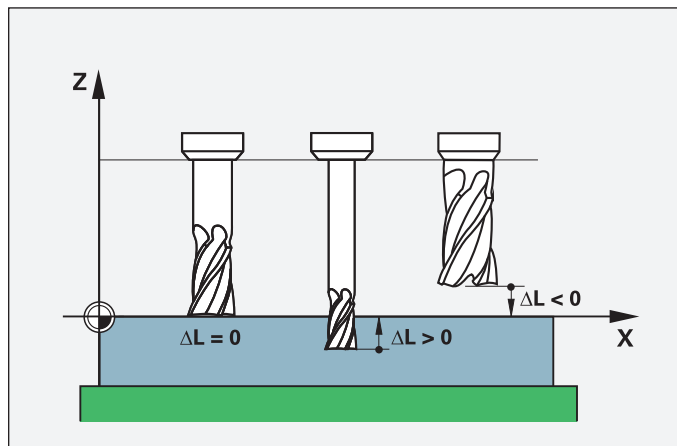
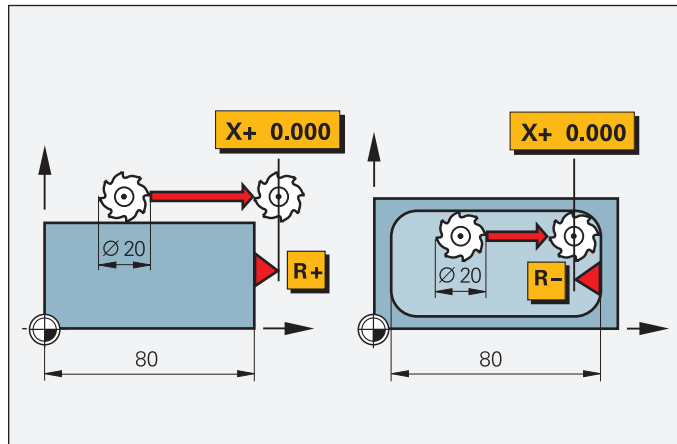

Determining and storing tool compensation values on lathes

The data of the tools stored for machining in the revolver or quick-change holder can be stored with the ND 5000, ND 7000 and POSITIP 8000:

- To do so, directly enter the tool position when turning the first diameter, or
- "freeze" the current axis position value, retract the tool, measure the turned diameter and then enter the value into the readout.

Changing presets

You can define a new preset for a new workpiece or a changed preset. The tool data are automatically referenced to the new preset and do not need to be modified.

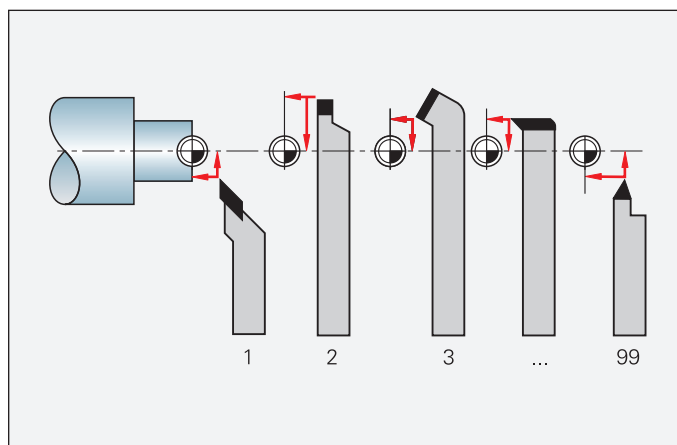

Functions

Distance-to-go display

Distance-to-go display for turning and milling

The distance-to-go display greatly simplifies your work: after you have entered the next nominal position, the digital readout shows you the distance remaining to the target position. You simply move the axes until the display reads zero.

In milling, the display can also compensate for the cutter radius. This allows you to work directly with the drawing dimensions without having to calculate conversions. You no longer need to remember any complicated values.

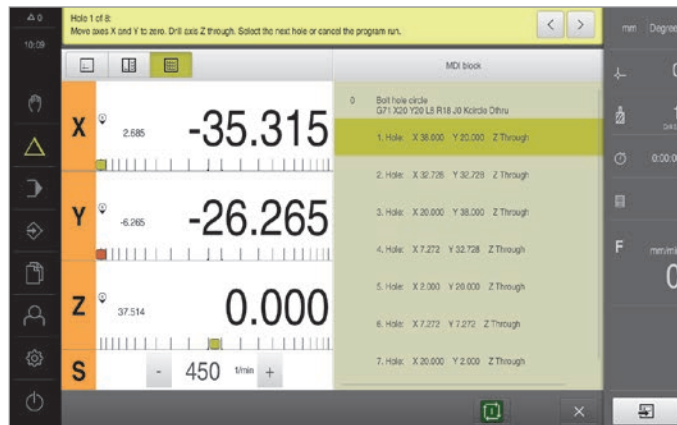
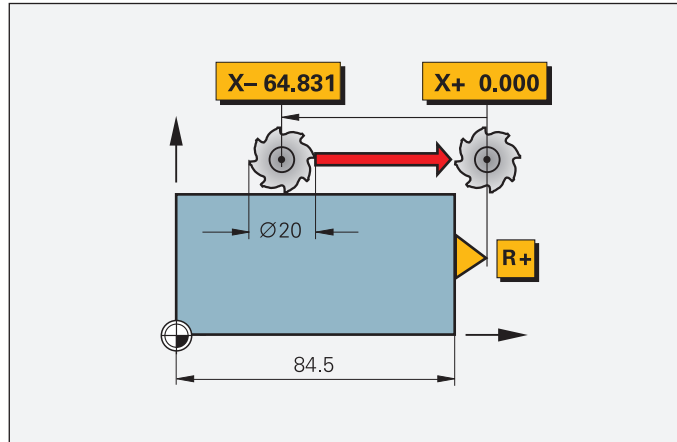

Hole patterns

Automatic calculation of hole patterns for milling and drilling

In milling machine mode you can machine **bolt hole circles** (full circle or circle segments) and **linear hole patterns** without having to calculate: You simply enter the geometric dimensions and the number of holes shown on the drawing. Based on these data, the readout calculates the coordinates of each hole in the working plane. You then simply move the axis to "zero" and drill. Afterwards, the display shows the next position. The **graphical display** is a particularly useful feature: it lets you verify all of your entered data for hole patterns prior to machining.

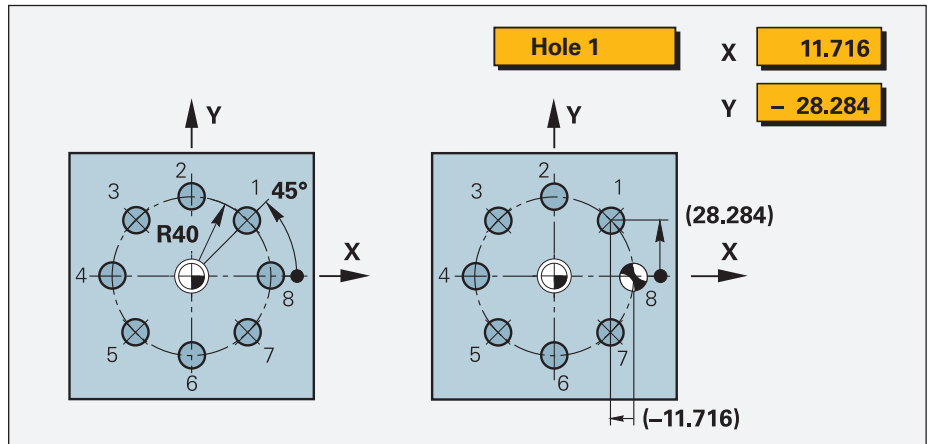

Functions

Aids for working with lathes

Radius/diameter display

In lathe mode, the positions of the cross slide can be displayed either as radius or diameter values. A button allows you to switch between them.

Sum display for longitudinal axes

In lathe mode, you can display the positions of the saddle and top slide either separately or as a sum:

- When **displayed separately**, the position values are referenced to the datum set for each axis slide. If the saddle alone is moved, the displayed value for the top slide remains unchanged.
- When **displayed as a sum**, the positions of both slides are added, taking their algebraic signs into account. You can then read the absolute position of the tool relative to the workpiece datum without performing calculations.

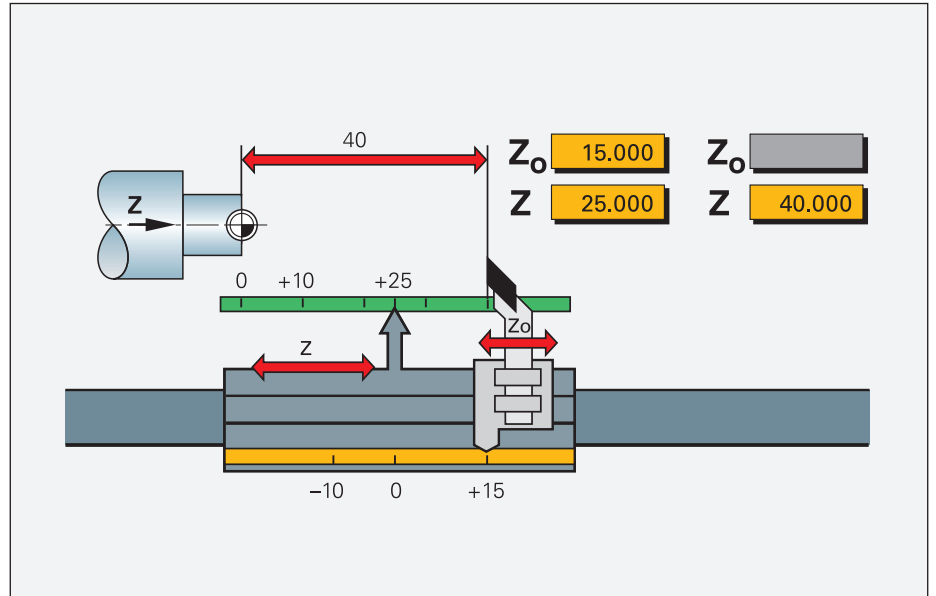

Taper turning made easy

If the taper dimensions do not directly provide the taper angle, then the integrated taper calculator helps you calculate it. You simply enter the taper ratio or both diameters and the length of the taper. You then immediately receive the angle that must be configured for the top slide.

Turning

For turning, simply enter the target dimensions and POSITIP will show you the distance to go in the longitudinal and transverse axes. You determine the best infeed increment.

Constant surface speed

Particularly in taper turning or parting, the surface speed changes based on the diameter. Yet a constant cutting speed is essential for attaining optimal machining results and long tool life. That's why the ND 7013 I/O and POSITIP 8016 ACTIVE digital readouts enable constant cutting-speed control based on the current workpiece diameter.

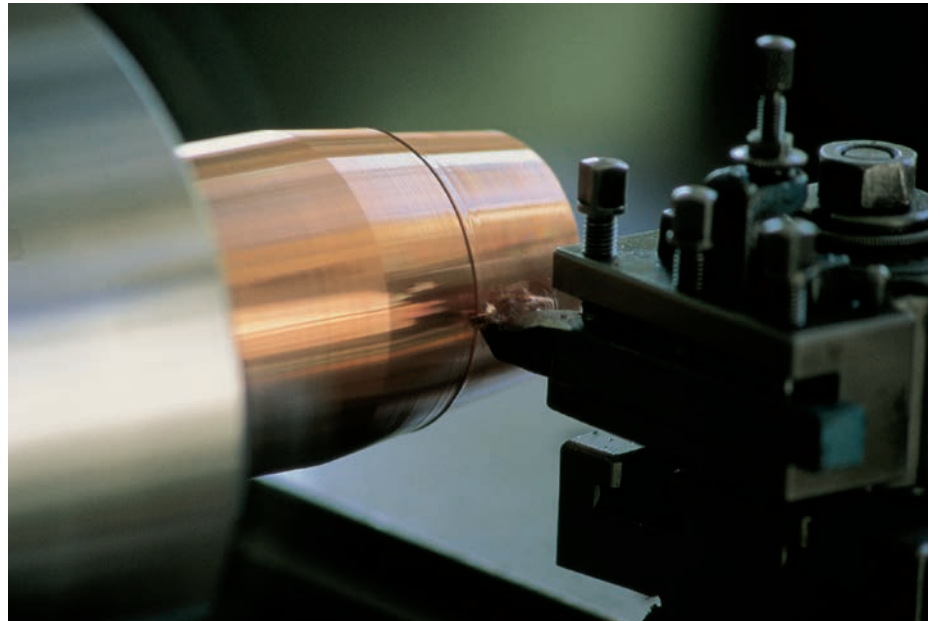

Programming of machining steps

The programming functions of the POSITIP 8000 (optionally available for the ND 7000) allow you to save repetitive machining steps as a program. For a small-batch part, for example, all of the operating sequences can be compiled into a single program. In the *Program Run* mode, the distance-to-go display guides you to the programmed positions in sequence.

You can create programs by manually entering each position or by simply saving the actual position value (teach-in programming).

The **POSITIP 8016 ACTIVE** also supports the execution of programs with NC-controlled axes, allowing you to machine your workpieces particularly fast and effectively using automation. The program can also control the spindle.

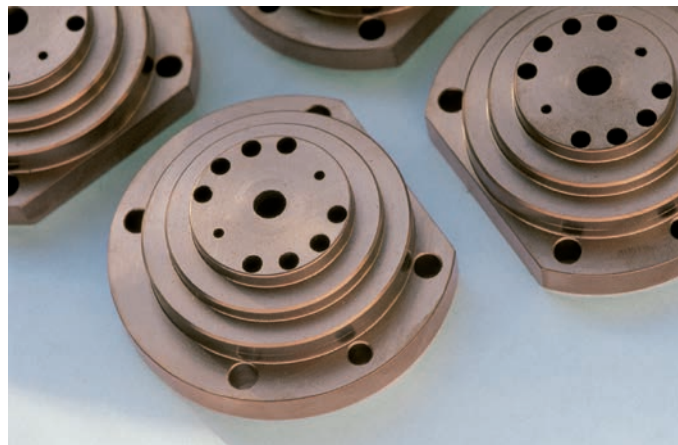
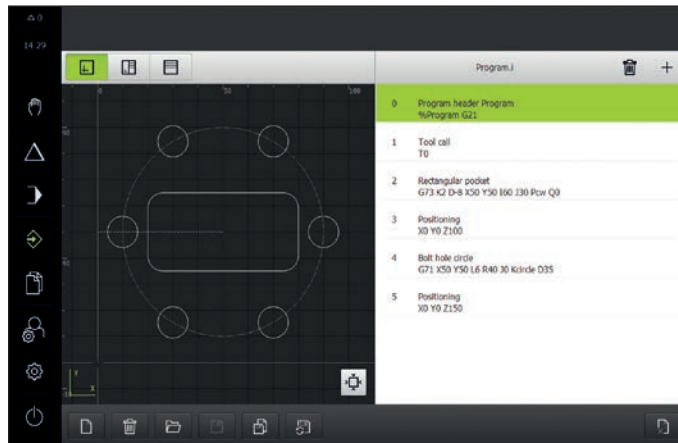
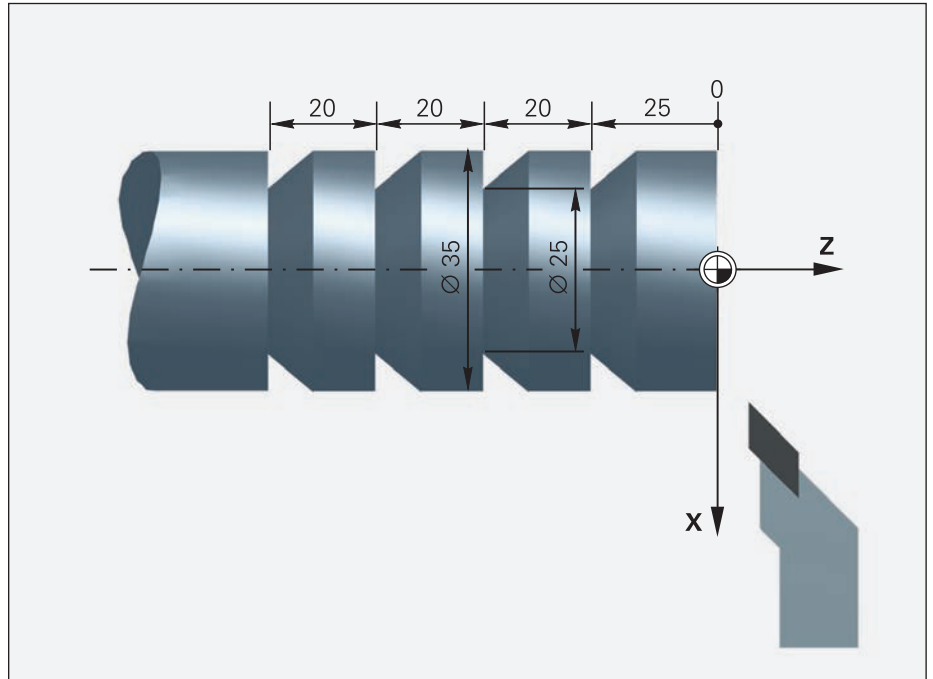

ND 5000

Digital readout for milling machines, drilling machines and lathes with up to three axes

The ND 5000 digital readout is suitable for use on manually operated milling and drilling machines, as well as on lathes with up to three axes. Due to the TTL encoder input, the LS 328 C and LS 628 C linear encoders with a display step of 5 µm are primarily used.

Design

The ND is designed for harsh shop environments. It features a sturdy aluminum housing and a splash-proof membrane keyboard.

With their intuitive and user-friendly interface, the ND digital readouts are particularly easy to operate. Everything you need to know for machining your workpiece is displayed on an easy to read 7-inch screen.

The symmetrical design of the ND ensures ergonomic operation. The ND digital readout's keyboard is conveniently accessible and its screen is easy to read.

Functions

The ND offers many useful functions for machining with manually operated machine tools. The most important functions are readily accessible directly through function keys. Soft keys with language-sensitive information in plain language enable context-sensitive operation.

Distance-to-go mode comes to your aid during positioning tasks. With it, you can easily and reliably arrive at the next position by simply moving the axes until the display reads zero.

Of course, the ND also offers special functions for milling and turning operations, such as:

- Hole patterns (linear, circular)
- Radius/diameter switching
- Sum display for the top slide

You can individually configure the display of the ND and save your settings in the user administration.

Data interface

A USB interface permits the import and export of parameters and tables to memory or to a PC.



Dynamic zoom

The axis currently in motion can be graphically highlighted. In "dynamic zoom" mode, the position value is enlarged to its maximum size based on the number of digits. This greatly improves readability—especially from far away.

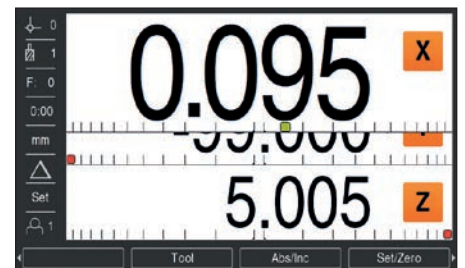

Installation guide

When you turn on the digital readout for the first time, the ND supports you with its installation guide, which leads you step by step through the most important settings until the device is ready for operation.



Day/night switching

You can also switch the screen of the ND to a light or dark background depending on the amount of ambient light at the machine.





ND 5023	
Axes	Up to 3 axes
Encoder inputs	□□TTL
Input frequency	≤ 500 kHz
Signal period	2 μm, 4 μm, 10 μm, 20 μm, 40 μm, 100 μm, 10240 μm, 12800 μm
Line count	Any
Display step¹⁾	<i>Linear axis:</i> 1 mm to 0.0001 mm; 0.005 mm with LS 328C/LS 628C <i>Rotary axis:</i> 1° to 0.0001° (00° 00' 01'')
Display	7-inch screen (15:9), resolution: 800 x 480 pixels for position values, dialog messages, data entry and graphical functions
Functions	<ul style="list-style-type: none"> • User administration and file management • 10 presets, 16 tools • Reference mark evaluation for distance-coded and single reference marks • Distance-to-go mode with nominal position input in absolute or incremental dimensions • Graphical positioning aid • Scaling factor • Integrated help system
For milling and drilling	<ul style="list-style-type: none"> • Calculation of positions for hole patterns (circular, linear) • Tool radius compensation • Cutting data calculator
For turning	<ul style="list-style-type: none"> • Freeze tool position during retraction • Sum display of axes in the top slide • Inclined top slide • Taper calculator
Error compensation	Linear (LEC) and segmented linear (SLEC) via up to 200 compensation points
Data interface	USB 2.0 Type C
Accessories	Single-Pos stand, Multi-Pos holder, mounting frame, protective cover, power cable
Power connection	AC 100 V to 240 V (±10 %); 50 Hz to 60 Hz (±5 %); ≤ 33 W
Operating temperature	0 °C to +45 °C (storage temperature: -20 °C to +70 °C)
Protection EN 60529	IP54; back panel: IP40
Mounting	Single Pos stand, Multi-Pos holder; fastening systems compatible with VESA MIS-D 100
Mass	≈ 1.7 kg

¹⁾ Depends on the signal period or line count of the connected encoder

ND 7000

Digital readout for milling machines, drilling machines and lathes with up to three axes

The ND 7000 digital readouts are suitable for use on any type of machine with up to three axes:

- Milling machines
- Lathes
- Radial drills
- Grinding machines
- Drilling and boring machines

Integrated switching inputs and outputs permit interaction with the machine and enable the implementation of simple automated tasks.

Design

The ND 7000 digital readouts are designed for harsh shop environments. They feature a sturdy aluminum housing with touchscreen operation. With their intuitive and user-friendly interface, the ND digital readouts are particularly easy to operate. Everything you need to know for machining your workpiece is displayed on an easy to read 7-inch screen. The low-profile aluminum housing, featuring an integrated power supply unit and fanless passive cooling system, is extremely rugged and durable. Its intuitive touchscreen made of specially hardened glass can even be operated with gloves.

Functions

The ND digital readouts offer many useful functions for machining with manually operated machine tools. Self-explanatory operating elements and language-sensitive information in plain language permit context-sensitive operation. Distance-to-go mode comes to your aid during positioning tasks. With it, you can easily and reliably arrive at the next position by simply moving the axes until the display reads zero.

Of course, the ND digital readouts also offer special functions for milling and turning operations, such as:

- Hole patterns (linear, circular)
- Radius/diameter switching
- Sum display for the top slide



Presets can be found fast and accurately with an edge finder. The ND digital readouts support you with special probing functions.

You can individually configure the display of the ND digital readouts and save your settings in the user administration.

Data interface

A USB port allows you to import and export configuration files.

Software options

Software options allow you to adapt the capabilities of the ND 7000 digital readouts to the given requirements. These software options can be activated by entering a license key. Please contact HEIDENHAIN for more information.

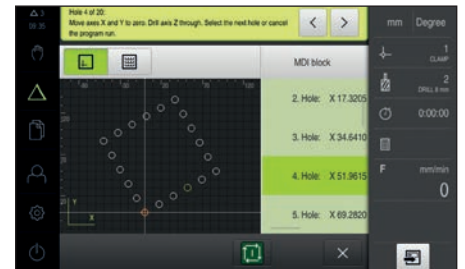



	ND 7013	ND 7013 I/O
Axes	Up to 3 axes	
Encoder inputs	$\sim 1 V_{PP}$, $\sim 11 \mu A_{PP}$, EnDat 2.2	
Display step¹⁾	Linear axis: 1 mm to 0.00001 mm	
Display	7-inch screen for touch operation; resolution: 800 x 480 pixels for position values, dialog boxes, data entry and graphical functions	
Functions	<ul style="list-style-type: none"> • User administration and file management • 100 presets, 100 tools • Reference mark evaluation for distance-coded and single reference marks • Distance-to-go mode with nominal position input in absolute or incremental dimensions • Graphical positioning aid • Scaling factor • Program creation and execution with up to 100 machining blocks (PGM software option) 	
For milling and drilling	<ul style="list-style-type: none"> • Calculation of positions for hole patterns (circular, linear) • Tool radius compensation • Cutting data calculator • Probing functions for preset finding (edge, centerline and circle) • Switching functions 	
	–	<ul style="list-style-type: none"> • Display and control the spindle speed
For turning	<ul style="list-style-type: none"> • Measurement of tool dimensions • Sum display of axes in the top slide • Taper calculator • Switching functions 	
	–	<ul style="list-style-type: none"> • Constant cutting speed • Display and control the spindle speed
Error compensation	Linear (LEC) and segmented linear (SLEC)	
Data interface	1 x Ethernet 100 Mbit / 1 Gbit (RJ45), 1 x USB 2.0 (Type A)	
Accessories	Single-Pos/Duo-Pos/Multi-Pos stands, Multi-Pos holder, mounting frame, power cable and adapter connector	
Power connection	AC 100 V to 240 V ($\pm 10\%$); 50 Hz to 60 Hz ($\pm 5\%$); $\leq 38 W$	
Operating temperature	0 °C to +45 °C (storage temperature: –20 °C to +70 °C)	
Protection EN 60529	IP65; back panel: IP40	
Mounting	Single-Pos stand, Duo-Pos stand, Multi-Pos stand, Multi-Pos holder, fastening systems with a 50 mm x 50 mm hole pattern	
Mass	≈ 1.30 kg	≈ 1.50 kg

¹⁾ Depends on the signal period or line count of the connected encoder

Connectivity comparison: ND 7013 versus ND 7013 I/O

	ND 7013	ND 7013 I/O
Encoder interfaces (11 μ A _{PP} , 1 V _{PP} , EnDat 2.2)	3	3
Digital inputs		
TTL 0 V to 5 V	4	4
High: DC 11 V to 30 V, 2.1 mA to 6.0 mA Low: DC 3 V to 2.2 V, 0.43 mA	–	24
Digital outputs		
TTL 0 V to +5 V, maximum load = 1 k Ω	1	1
DC 24 V (20.4 V to 28.8 V); max. 150 mA per channel	–	8
Relay outputs Max. switching voltage: AC/DC 30 V; max.: 0.5 A; max. 15 W; max. continuous current: 0.5 A	–	2
Analog inputs Voltage range: DC 0 V to 5 V Resistance range: 100 Ω \leq R \leq 50 k Ω	–	4
Analog outputs Voltage range: DC –10 V to +10 V Maximum load: 1 k Ω	–	4
5 V voltage outputs Voltage tolerance: \pm 5 %; maximum current: 100 mA	–	1
Touch probe connection Voltage supply: DC 5 V or DC 12 V		
Digital inputs: TTL 0 V to +5 V (low active)	4	4
Digital outputs: TTL 0 V to 5 V, maximum load = 1 k Ω	1	1



Further information:

Operating instructions
 ND 7000 – Milling ID 1308766-xx
 ND 7000 – Turning ID 1308767-xx
 Or on the Internet under
www.heidenhain.com/service/downloads/documentation

User-controlled functions

Type	Function	ND 7013	ND 7013 I/O
Logo	Call-up of operating instructions or OEM service information	✓	✓
Spindle speed	Pre-assignment of spindle speeds (radio buttons)	–	✓
M function	Freely definable functions	–	✓
Special functions	Selection between thread cutting, direction of spindle rotation, coolant during spindle operation, or clamping of axes	–	✓
	Zeroing of the tool axis	✓	✓
Document	Display of tables (e.g., thread tables, cutting speeds)	✓	✓

POSITIP 8000

Digital readout for milling machines, drilling machines and lathes with up to six axes

POSITIP 8000 digital readouts are suitable for manually operated milling machines, drilling machines and lathes with up to six axes. Integrated switching inputs and outputs permit interaction with the machine and enable the implementation of simple automated tasks.

With the POSITIP 8016 ACTIVE, up to three NC axes plus a spindle can be configured and controlled. The simultaneous movement of multiple axes and functions for machine safety are not supported.

Design

The POSITIP 8000 digital readouts are designed for harsh shop environments. They feature a sturdy aluminum housing with touchscreen operation.

Thanks to the intuitive, user-friendly graphical user interface, the POSITIP digital readouts are particularly easy to operate. Everything you need to know for machining your workpiece is displayed on an easy to read 12-inch screen.

The low-profile aluminum housing, featuring an integrated power supply unit and fanless passive cooling system, is extremely rugged and durable. Its intuitive touchscreen made of specially hardened glass can even be operated with gloves.

Functions

The POSITIP 8000 digital readouts offer many useful functions for machining with manually operated machine tools. Self-explanatory operating elements and language-sensitive information in plain language permit context-sensitive operation.



Distance-to-go mode comes to your aid during positioning tasks. With it, you can easily and reliably arrive at the next position by simply moving the axes until the display reads zero. This feature is particularly useful during the execution of programs.

Of course, the POSITIP 8000 digital readouts also offer special functions for milling and turning operations, such as:

- Hole patterns (linear, circular)
- Radius/diameter switching
- Sum display for the top slide

Presets can be found fast and accurately with an edge finder. The POSITIP digital readouts support you with special probing functions.

You can individually configure the POSITIP 8000 digital readouts and save your settings in the user administration.

Data interface

A USB port allows you to import and export configuration files and programs. The Ethernet interface allows programs to be saved or imported over a network.

Software options

Software options allow you to adapt the capabilities of the POSITIP 8000 digital readouts to the given requirements. These software options can be activated by entering a license key. Please contact HEIDENHAIN for more information.



	POSITIP 8016	POSITIP 8016 ACTIVE
Axes	Up to 6 axes (4 axes in the standard version; 2 additional axes available as a software option)	
Encoder inputs	$\sim 1 V_{PP}$, $\sim 11 \mu A_{PP}$, EnDat 2.2	
Display step¹⁾	Linear axis: 1 mm to 0.00001 mm	
Display	12-inch screen for touch operation; resolution: 1280 x 800 pixels for position values, dialog boxes, data entry and graphical functions	
Functions	<ul style="list-style-type: none"> • Creation and execution of programs • User administration and file management • 100 presets, 100 tools • Reference mark evaluation for distance-coded and single reference marks • Distance-to-go mode with nominal position input in absolute or incremental values • Graphical positioning aid • Scaling factor 	
For milling and drilling	<ul style="list-style-type: none"> • Calculation of positions for hole patterns (circular, linear) • Tool radius compensation • Cutting data calculator • Probing functions for preset finding (edge, centerline and circle) • Switching functions 	
	–	Control of up to 3 NC axes and a spindle
For turning	<ul style="list-style-type: none"> • Measurement of tool dimensions • Sum display of axes in the top slide • Taper calculator • Switching functions 	
	–	Control of up to 3 NC axes and a spindle; constant surface speed
Error compensation	Linear (LEC) and segmented linear (SLEC)	
Data interface	2 x Ethernet 100 Mbit/1 Gbit (RJ45), 4 x USB 2.0 (Type A)	
Accessories	Single-Pos/Duo-Pos/Multi-Pos stands, Multi-Pos holder, mounting frame, power cable and adapter connector	
Power connection	AC 100 V to 240 V ($\pm 10\%$), 50 Hz to 60 Hz ($\pm 5\%$) POSITIP 8016 ACTIVE: $\leq 79 W$; POSITIP 8016: $\leq 38 W$	
Operating temperature	0 °C to +45 °C (storage temperature: -20 °C to +70 °C)	
Protection EN 60529	IP65; back panel: IP40	
Mounting	Single-Pos stand, Duo-Pos stand, Multi-Pos stand, Multi-Pos holder, fastening systems compatible with VESA MIS-D 100	
Mass	≈ 3.50 kg	

¹⁾ Depends on the signal period or line count of the connected encoder

Connectivity comparison: POSITIP 8016 versus POSITIP 8016 ACTIVE

	POSITIP 8016	POSITIP 8016 ACTIVE
Encoder interfaces (11 μ APP, 1 VPP, EnDat 2.2)	4 2 additional ones as a software option	4 2 additional ones as a software option
Digital inputs		
TTL 0 V to 5 V	8	8
High: DC 11 V to 30 V, 2.1 mA to 6.0 mA Low: DC 3 V to 2.2 V, 0.43 mA	–	24
Digital outputs		
TTL 0 V to +5 V, maximum load = 1 k Ω	16	16
DC 24 V (20.4 V to 28.8 V); max. 150 mA per channel	–	8
Relay outputs Max. switching voltage: AC/DC 30 V; max.: 0.5 A; max. 15 W; max. continuous current: 0.5 A	–	2
Analog inputs Voltage range: DC 0 V to 5 V Resistance range: 100 Ω \leq R \leq 50 k Ω	–	4
Analog outputs Voltage range: DC –10 V to +10 V Maximum load: 1 k Ω	–	4
5 V voltage outputs Voltage tolerance: \pm 5 %; maximum current: 100 mA	1	2



Further information:

Operating instructions
 POSITIP 8000 – Milling ID 1317302-xx
 POSITIP 8000 – Turning ID 1317303-xx
 Or on the Internet under
www.heidenhain.com/service/downloads/documentation

User-controlled functions

Type	Function	PT 8016	PT 8016 ACTIVE
Logo	Call-up of operating instructions or OEM service information	✓	✓
Programming	–	✓	✓
Spindle speed	Pre-assignment of spindle speeds (radio buttons)	–	✓
M function	Freely definable functions	✓	✓
	Direction of spindle rotation	–	✓
	Coolant during spindle operation	–	✓
	Clamping of axes	–	Only with NC software option
	Coolant	–	✓
	Zeroing of the tool axis	✓	✓
Document	Display of tables (e.g., thread tables, cutting speeds)	✓	✓

Mounting and accessories

Types of mounting

The digital readouts feature setup flexibility thanks to the Single-Pos, Duo-Pos and Multi-Pos stands. The Multi-Pos holder and the mounting frame are suitable for mounting onto the machine.

ND 5000 mounting types

- Single-Pos stand
- Multi-Pos holder on mounting arm
- Mounting frame

ND 7000 mounting types

- Single-Pos stand
- Duo-Pos stand
- Multi-Pos stand
- Multi-Pos holder on mounting arm
- Mounting frame

POSITIP 8000 mounting types

- Single-Pos stand
- Duo-Pos stand
- Multi-Pos stand
- Multi-Pos holder on mounting arm
- Mounting frame

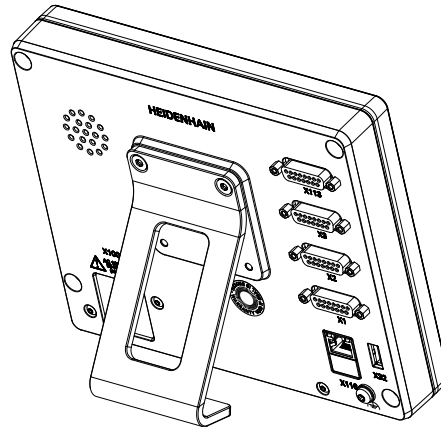

Single-Pos stand
(example: ND 7013)

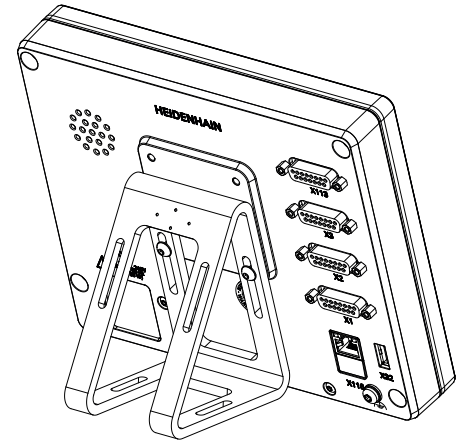

Duo-Pos stand
(example: ND 7013)

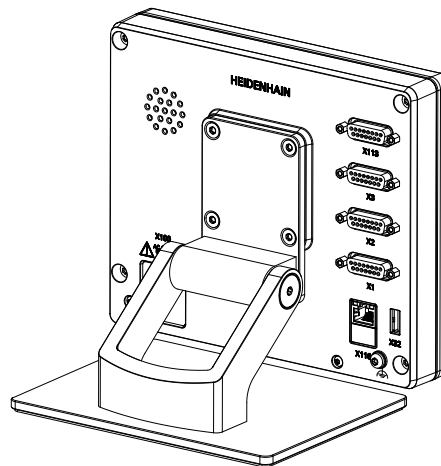

Multi-Pos stand
(example: ND 7013)

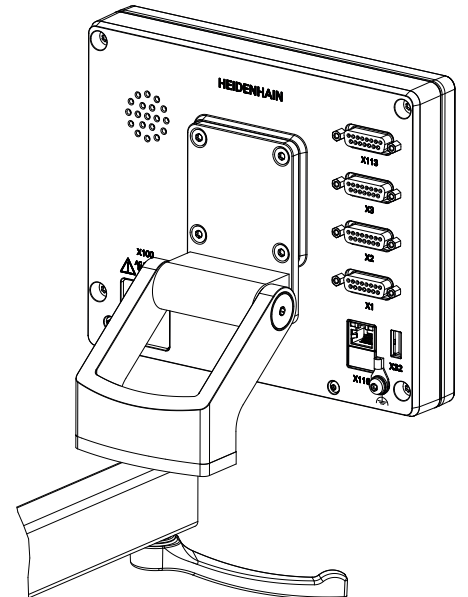

Multi-Pos holder on mounting arm
(example: ND 7013)

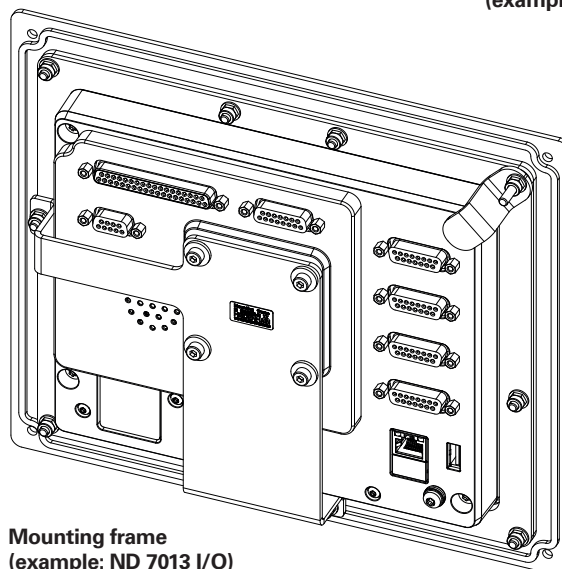

Mounting frame
(example: ND 7013 I/O)

ND 5000 dimensions

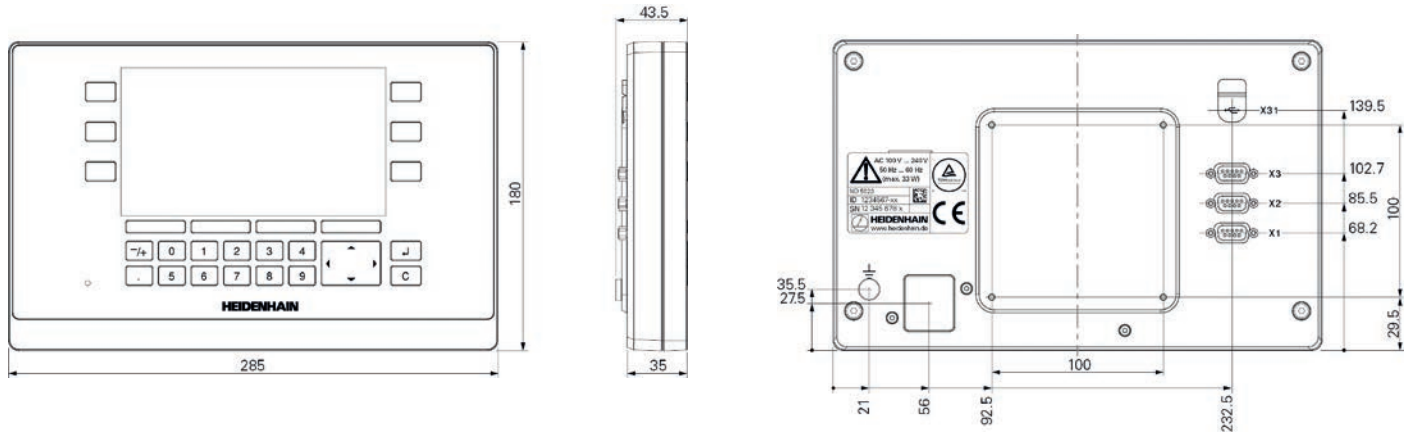

ND 5000 accessories

Single-Pos stand

Included in delivery. For setup on and fastening to a surface (20° tilt).

ID 1197273-01

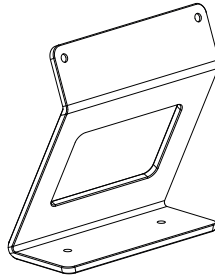

Mounting arm, straight

For mounting onto a machine.

ID 1089207-01

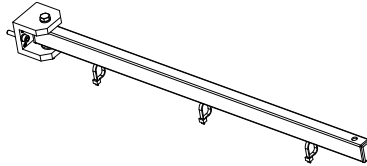

Tilt/swivel set

Holder for mounting arm

ID 1298187-01

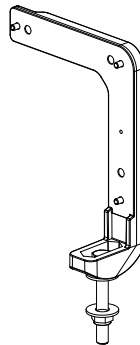

Mounting frame

For integration into a panel.

ID 1197274-01

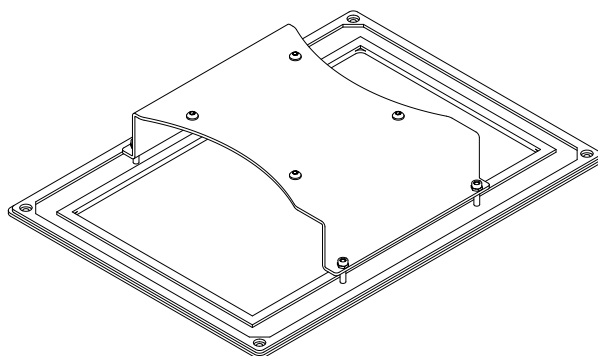

Mounting and accessories

ND 7000 dimensions

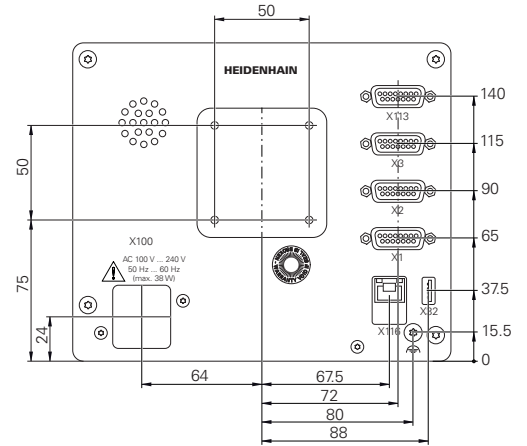
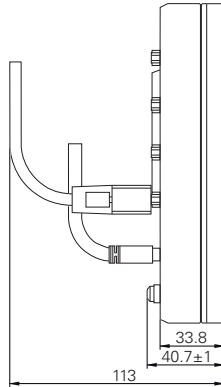
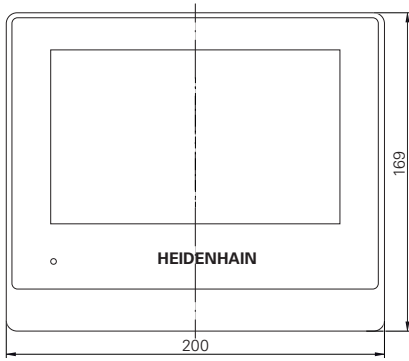

Rear panel of the ND 7013

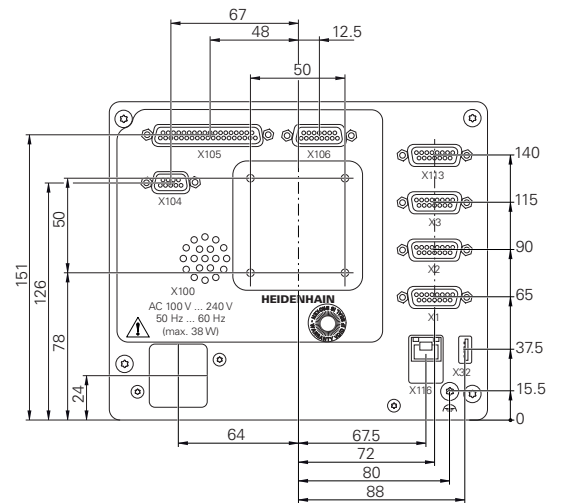
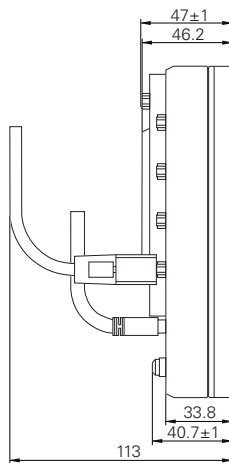

Rear panel of the ND 7013 I/O

ND 7000 accessories

Single-Pos stand

Included in delivery. For setup on and fastening to a surface (20° tilt).

ID 1089230-05



Multi-Pos stand

For setup on and fastening to a horizontal surface (90° continuous tilt range).

ID 1089230-07

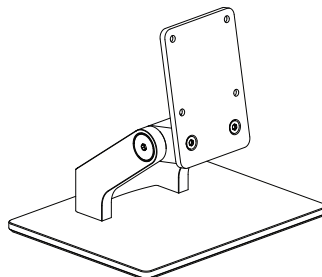

Duo-Pos stand

For setup on and fastening to a horizontal surface (20° or 45° tilt).

ID 1089230-06

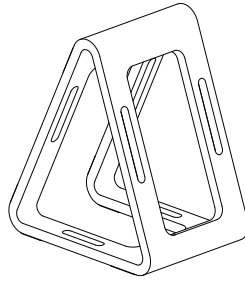

Mounting arm, straight

For fastening to a machine.

ID 1089207-01

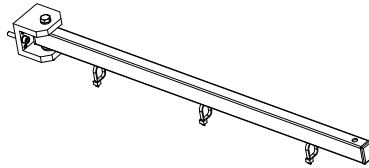

Multi-Pos holder

For fastening to an arm (90° continuous tilt range).

ID 1089230-08

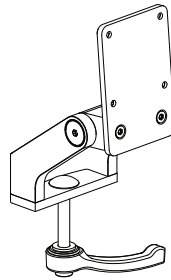

Mounting frame

For integration into a panel.

ID 1089208-01

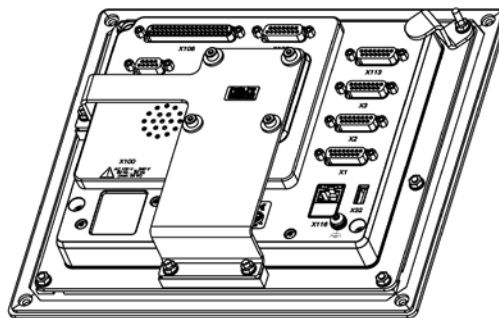

Adapter connector

For pin layout conversion after a replacement (e.g., from ND 780 to ND 7000).

ID 1089214-01



PC demo software under

www.heidenhain.com/software

► Digital Readouts ► ND 7000 ► Software DEMO

Mounting and accessories

POSITIP 8000 dimensions

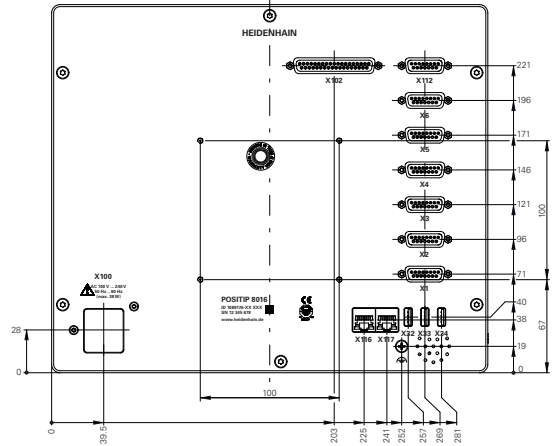
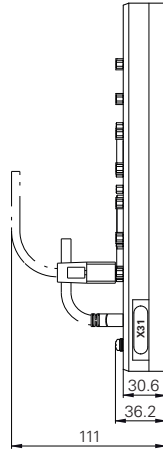
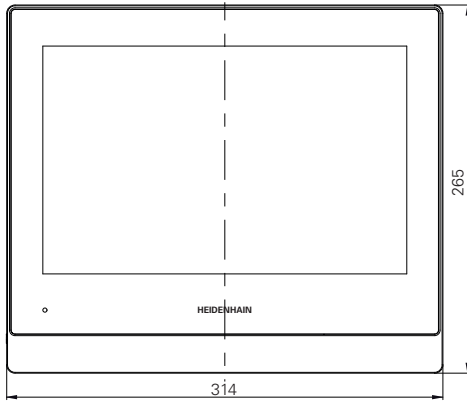

POSITIP 8016

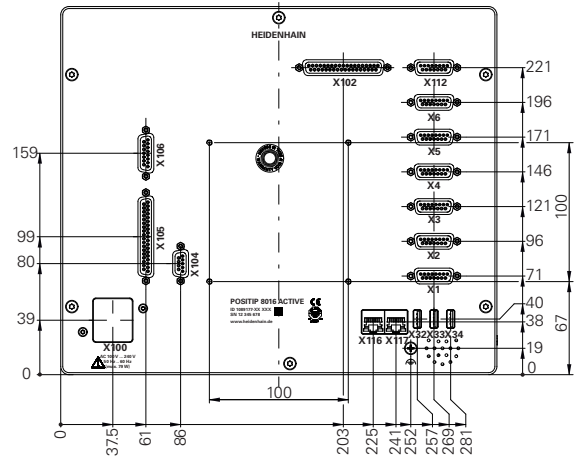
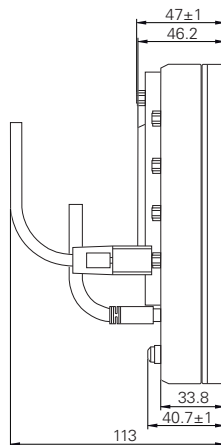

POSITIP 8016 ACTIVE

POSITIP 8000 accessories

Single-Pos stand

Included in delivery. For setup on and fastening to a surface (20° tilt).

ID 1089230-01

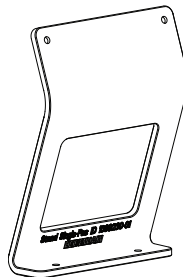

Multi-Pos stand

For setup on and fastening to a horizontal surface (90° continuous tilt range).

ID 1089230-03

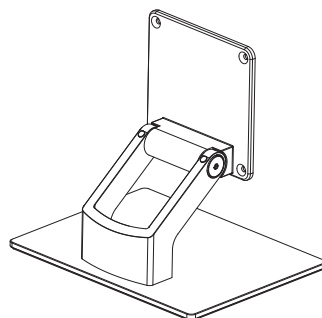

Duo-Pos stand

For setup on and fastening to a horizontal surface (20° or 45° tilt).

ID 1089230-02

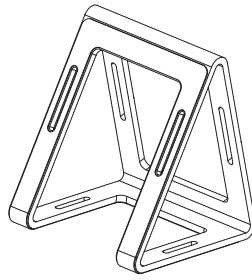

Mounting arm, straight

For fastening to a machine.

ID 1089207-01

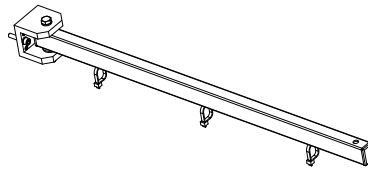

Multi-Pos holder

For fastening to an arm (90° continuous tilt range).

ID 1089230-04

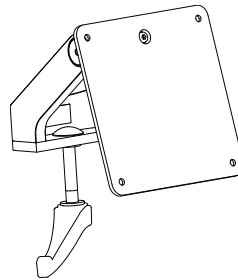

Mounting frame

For integration into a panel.

ID 1089208-02

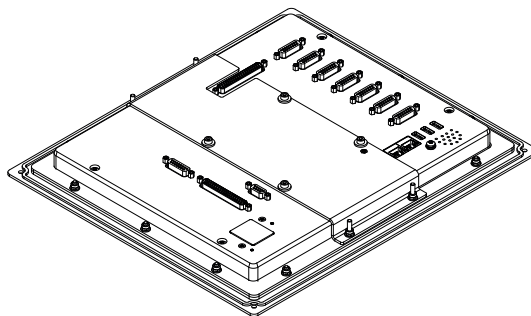

Adapter connector

For pin layout conversion after a replacement (e.g., from PT 880 to POSITIP 8000).

ID 1089214-01



PC demo software under

www.heidenhain.com/software

► Digital Readouts ► POSITIP 8000 ► Software DEMO

Linear encoders for machine tools

For typical applications on manual machine tools such as milling machines or lathes, **display steps of 10 µm or 5 µm** are sufficient. Suitable for these display steps are the LS 300 and LS 600 series linear encoders with an accuracy grade of $\pm 5 \mu\text{m}$ per meter of traverse.

Jig boring machines, grinding machines and measuring and inspection tasks normally require **display steps of 1 µm** and finer. Suitable linear encoders for these more stringent requirements typically feature accuracy grades of $\pm 5 \mu\text{m}$ per meter of traverse.

For **limited installation space** (e.g., on the slide of a lathe), the linear encoders with a slimline scale housing are suitable.

The linear encoders with a full-size scale housing are deployed as universal linear encoders under **normal mounting conditions**.

Linear encoders for long traverses

Long traverses of over three meters can be found on large boring mills or milling machines, but also on the long Z axes of lathes. HEIDENHAIN offers suitable linear encoders for specialized applications of this type as well.

LB 383 or **LC 200** encoders with a full-size scale housing enable **measuring lengths of up to 70040 mm** or **28040 mm**. The housing is assembled on the machine in sections and the single-piece steel scale tape is pulled through. The LB 383 and LC 200 can be found in the *Linear Encoders for Numerically Controlled Machine Tools* brochure.

Absolute linear encoders

Encoders for absolute position measurement are used on machines and equipment for which the axis positions must be known upon switch-on. The LC 415, LC 115 and LC 200 absolute linear encoders are described in the *Linear Encoders for Numerically Controlled Machine Tools* brochure.

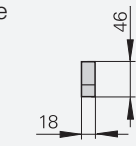
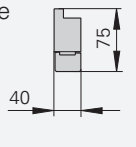
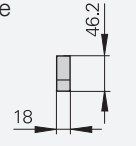
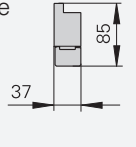
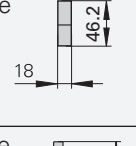
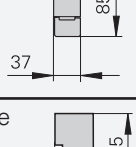
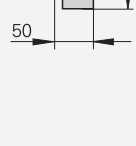
	Scale housing	Accuracy grade	Measuring lengths
Linear encoders for manually operated machine tools			
Incremental linear measurement • Glass scale	Slimline 	$\pm 5 \mu\text{m}$	70 mm to 1240 mm
	Full-size 	$\pm 5 \mu\text{m}$	140 mm to 3040 mm
Linear encoders for numerically controlled machine tools			
Incremental linear measurement • Glass scale	Slimline 	$\pm 5 \mu\text{m}$ $\pm 3 \mu\text{m}$	70 mm to 1240 mm <i>With mounting spar:</i> 70 mm to 2040 mm
	Full-size 	$\pm 5 \mu\text{m}$ $\pm 3 \mu\text{m}$	140 mm to 3040 mm
Absolute linear measurement • Glass scale	Slimline 	$\pm 5 \mu\text{m}$ $\pm 3 \mu\text{m}$	70 mm to 1240 mm <i>With mounting spar or clamping elements:</i> 70 mm to 2040 mm
	Full-size 	$\pm 5 \mu\text{m}$ $\pm 3 \mu\text{m}$	140 mm to 3040 mm
Incremental linear measurement for large measuring lengths • Steel scale tape	Full-size 	$\pm 5 \mu\text{m}$	440 mm to 30040 mm
Absolute linear measurement for large measuring lengths • Steel scale tape			4240 mm to 28040 mm

	Interface	Signal period	Model	Further information
	~ 1 V _{SS}	20 μm	LS 383C	Page 32
	□ TTL		LS 373C	
	~ 1 V _{SS}	20 μm	LS 683C	Page 34
	□ TTL	20 μm	LS 673C	
	~ 1 V _{PP}	20 μm	LS 487	Brochure: Linear Encoders for Numerically Controlled Machine Tools
	□ TTL	Down to 1 μm	LS 477	
	~ 1 V _{PP}	20 μm	LS 187	
	□ TTL	Down to 1 μm	LS 177	
	EnDat 2.2	–	LC 415	
	EnDat 2.2	–	LC 115	
	~ 1 V _{PP}	40 μm	LB 383	Brochure: Linear Encoders for Numerically Controlled Machine Tools
	EnDat 2.2 with ~ 1 V _{PP}	40 μm	LC 281	
	EnDat 2.2	–	LC 211	



LS 383C



LS 683C



LC 281/LC 211



LB 383

LS 300 series

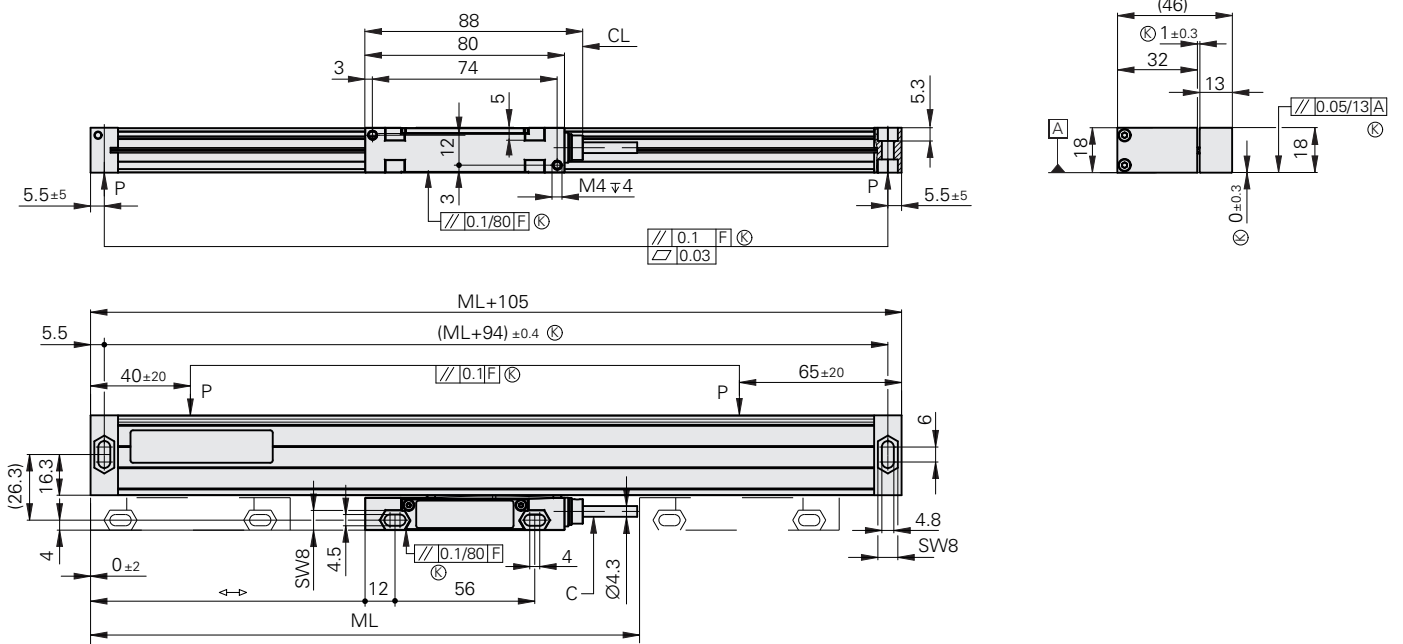

mm

Tolerancing ISO 8015
 ISO 2768:1989-mH
 ≤ 6 mm: ±0.2 mm

- F = Machine guideway
- ML = Measuring length
- P = Measuring points for alignment
- ↔ = 0 to ML
- C = Connecting cable
- CL = Cable length
- K = Required mating dimensions

LS 3x3(C)

Starting value for version with distance-coded reference marks between 0 mm and 3200 mm

Cable with metal armor

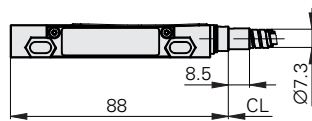

LS 477(C), LS 487(C)

Available on short notice as a replacement device
 Scanning-unit dimensions may vary

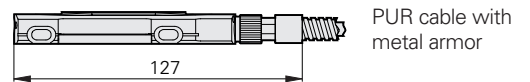
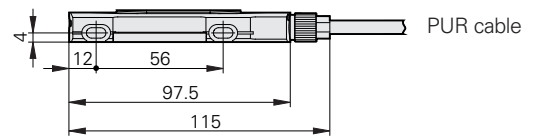



Specifications	LS 383 ¹⁾	LS 373 ²⁾												
Measuring standard Coefficient of linear expansion	Glass scale $\alpha_{\text{therm}} \approx 8 \cdot 10^{-6} \text{ K}^{-1}$													
Accuracy grade	$\pm 5 \mu\text{m}$													
Measuring length ML* in mm	70 770	120 820	170 870	220 920	270 970	320 1020	370 1140	420 1240	470	520	570	620	670	720
Reference marks	LS 3x3: One reference mark in the middle LS 3x3C: Distance-coded ³⁾													
Interface	$\sim 1 \text{ V}_{\text{PP}}$				\square TTL									
Signal period	20 μm													
Integrated interpolation	–				1-fold	5-fold	10-fold	20-fold						
Measuring step	–				5 μm	1 μm	0.5 μm	0.25 μm						
Supply voltage Without load	5V $\pm 0.25 \text{ V}$ / < 150 mA													
Electrical connection	PUR connecting cable and PUR cable with metal armor; cable outlet to the right on the mounting block													
Cable length	3 m, 6 m													
Connecting element	15-pin D-sub connector (male) 15-pin D-sub connector (female) 12-pin M23 connector (male)				15-pin D-sub connector (male) 9-pin D-sub connector (male) 12-pin M23 connector (male)									
Traversing speed	$\leq 60 \text{ m/min}$													
Required moving force	$\leq 5 \text{ N}$													
Vibration 55 Hz to 2000 Hz Shock 6 ms	$\leq 100 \text{ m/s}^2$ $\leq 200 \text{ m/s}^2$													
Operating temperature	0 °C to 50 °C													
Protection IEC 60529	IP53													
Mass without cable	0.3 kg + 0.57 kg/m of measuring length													

* Please select when ordering

¹⁾ The LS 487 is available as a replacement device through the HEIDENHAIN Service department on short notice

²⁾ The LS 477 is available as a replacement device through the HEIDENHAIN Service department on short notice

³⁾ Starting value for version with distance-coded reference marks between 0 mm and 3200 mm

LS 600 series

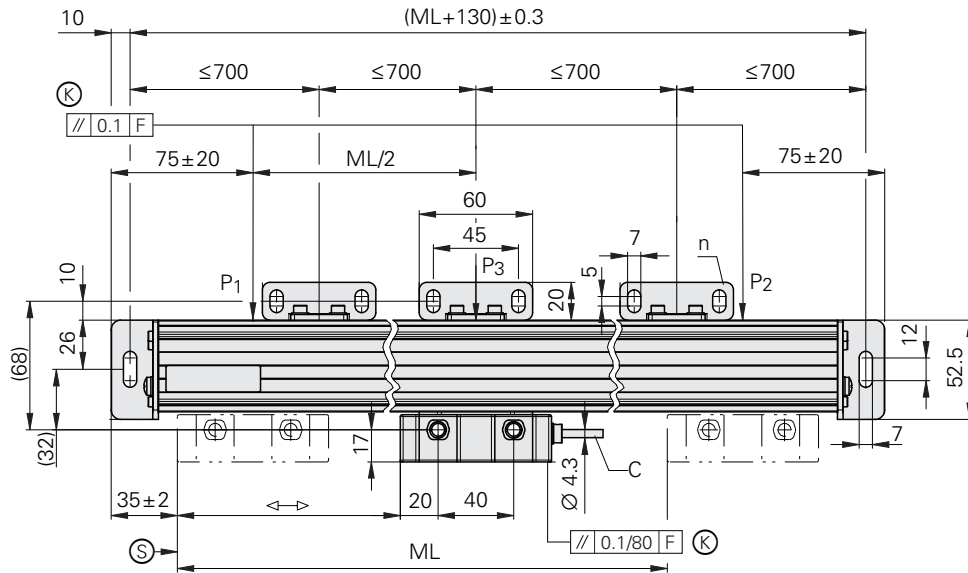
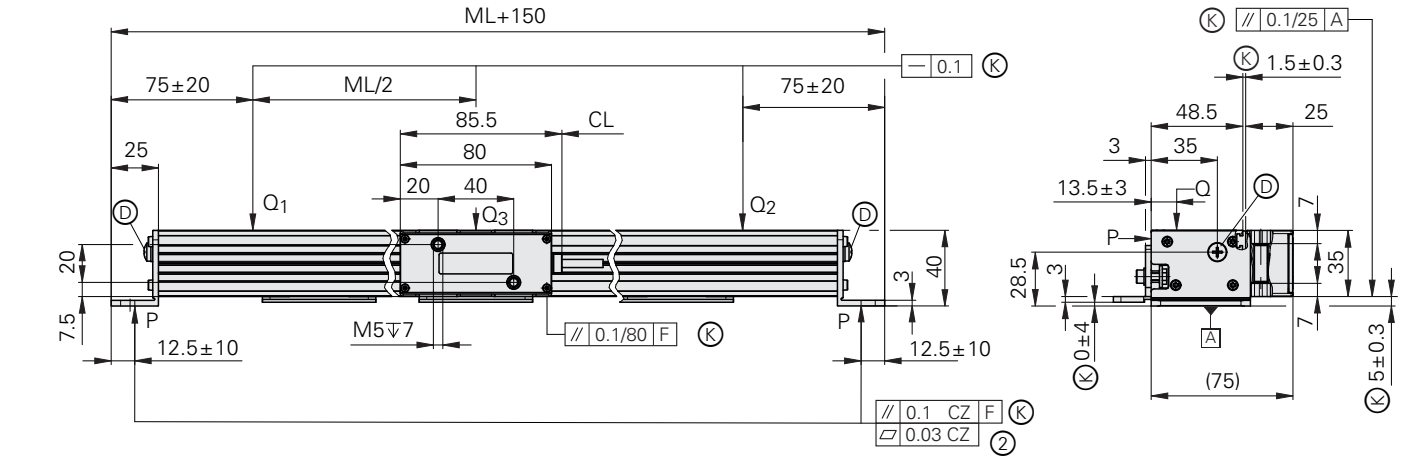

ML	n
≥ 620	1 x
≥ 1140	2 x
≥ 2040	3 x
≥ 2840	4 x

mm

 Tolerancing ISO 8015
 ISO 2768:1989-mH
 ≤ 6 mm: ± 0.2 mm

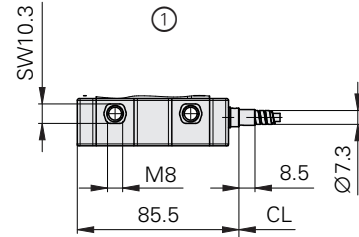

- F = Machine guideway
- ML = Measuring length
- P, Q = Measuring points
- C = PUR connecting cable
- CL = Cable length
- \leftrightarrow = 0 ... ML
- K = Required mating dimensions
- S = Beginning of measuring length ML
- D = Compressed-air inlet
- 1 = PUR cable in metal armor
- 2 = Mounting surface

LS 6x3(C)
 Starting value for version with distance-coded reference marks between 0 mm and 3200 mm



Specifications	LS 683 C	LS 673 C																																										
Measuring standard Coefficient of linear expansion	Glass scale $\alpha_{\text{therm}} \approx 8 \cdot 10^{-6} \text{ K}^{-1}$																																											
Accuracy grade	$\pm 5 \mu\text{m}$																																											
Measuring length (ML)* in mm	<table border="1"> <tr> <td>170</td><td>220</td><td>270</td><td>320</td><td>370</td><td>420</td><td>470</td><td>520</td><td>570</td><td>620</td><td>670</td><td>720</td><td>770</td><td>820</td> </tr> <tr> <td>870</td><td>920</td><td>970</td><td>1020</td><td>1140</td><td>1240</td><td>1340</td><td>1440</td><td>1540</td><td>1640</td><td>1740</td><td>1840</td><td>2040</td><td>2240</td> </tr> <tr> <td>2440</td><td>2640</td><td>2840</td><td>3040</td><td></td><td></td><td></td><td></td><td></td><td></td><td></td><td></td><td></td><td></td> </tr> </table>		170	220	270	320	370	420	470	520	570	620	670	720	770	820	870	920	970	1020	1140	1240	1340	1440	1540	1640	1740	1840	2040	2240	2440	2640	2840	3040										
170	220	270	320	370	420	470	520	570	620	670	720	770	820																															
870	920	970	1020	1140	1240	1340	1440	1540	1640	1740	1840	2040	2240																															
2440	2640	2840	3040																																									
Reference mark	Distance-coded ¹⁾																																											
Interface	$\sim 1 \text{ V}_{\text{PP}}$	\square TTL																																										
Signal period	20 μs																																											
Integrated interpolation	–	1-fold																																										
Measuring step	–	5 μm																																										
Supply voltage Without load	5V $\pm 0.25 \text{ V}$ / < 150 mA																																											
Electrical connection	PUR cable and PUR cable with metal armor; cable outlet to the right on the mounting block																																											
Cable length	3 m, 6 m																																											
Connecting element	15-pin D-sub connector (male) 15-pin D-sub connector (female) 12-pin M23 connector (male)	15-pin D-sub connector (male) 9-pin D-sub connector (male) 12-pin M23 connector (male)																																										
Traversing speed	$\leq 60 \text{ m/min}$																																											
Required moving force	$\leq 5 \text{ N}$																																											
Vibration 55 Hz to 2000 Hz Shock 6 ms	$\leq 100 \text{ m/s}^2$ $\leq 200 \text{ m/s}^2$																																											
Operating temperature	0 °C to 50 °C																																											
Protection IEC 60529	IP53 (IP64 with sealing air via DA 400)																																											
Mass without cable	0.45 kg + 2.24 kg/m of measuring length																																											

* Please select when ordering

¹⁾ Starting value for version with distance-coded reference marks between 0 mm and 3200 mm

HEIDENHAIN

Mastering nanometer accuracy



HEIDENHAIN

DR. JOHANNES HEIDENHAIN GmbH
Dr.-Johannes-Heidenhain-Straße 5
83301 Traunreut, Germany
☎ +49 8669 31-0
☎ +49 8669 32-5061
info@heidenhain.de
www.heidenhain.com



HEIDENHAIN
worldwide